

PATENT SPECIFICATION



Application Date: Feb. 13, 1935. No. 4631/35.

433,925

Complete Specification Left : Feb. 13, 1935.

Complete Specification Accepted: Aug. 22, 1935.

PROVISIONAL SPECIFICATION

Improvements in and relating to Seaplanes

We, THE BLACKBURN AEROPLANE AND MOTOR COMPANY LIMITED, a Company organised under the Laws of Great Britain, and JOHN DOUGLAS RENNIE, a British Subject, both of Seaplane Base, Brough, near Hull, East Yorkshire, do hereby declare the nature of this invention to be as follows:—

This invention relates to seaplanes which are constructed so that the floats or boats or sections of them are arranged to be lowered for supporting the aircraft on water, and when the take-off has been accomplished such floats or boats or sections are raised into positions where they create less drag than if they were maintained in the low position which they are required to occupy when the machine is water-borne in order to bring the propelling plant of the air propellers above the region where they are likely to be damaged by contact with heavy spray or water. The main boat or boats are constructed with a lower section or pontoon which can be separated from the upper section and held down at a predetermined position by raising and lowering mechanism such as, for instance, hydraulic cylinders operating on suitable guides or by a combination of hydraulic cylinders and parallel control links which permit the pontoon to swing downwards and forwards.

In such seaplanes the float, boat or pontoon (hereinafter referred to as "the pontoon"), when lowered and floating on the water, will determine the angular setting of the wings and at a certain position the wings will have an optimum value for the take-off. Also, when the pontoon is raised in flight there will be a certain position of the hull in relation to the wings which will give the best condition for flight.

The object of the present invention is to enable the best setting of the parts for both the take-off and the flight to be obtained.

According to this invention, the raising and lowering mechanism is arranged to give a differential effect in raising and lowering the pontoon so that the optimum angular setting between the pontoon and

the wings for take-off, and also the best wing setting relatively to the hull for flight conditions, can be obtained.

The raising and lowering of the pontoon may be effected in many ways, such as, for instance, by fore and aft hydraulic cylinders. The pontoon may be carried on fore and aft links and these links may be parallel so as to permit the pontoon to swing downwards and forwards when lowered, or upwards and rearwards when raised, by the hydraulic cylinders. These links are preferably in the form of frames having a wide base on the fixed portion of the hull or float and on the pontoon and the fore links are made longer than the aft links or otherwise arranged that the arc through which the aft links are swung is smaller than that of the fore links in order to provide the required differential movement of the pontoon. The aft hydraulic cylinder or cylinders are also made smaller than the fore cylinder or cylinders.

The hydraulic cylinders, of which there are preferably two forward and two aft, are in communication, by conduits forming a closed circulatory system, with a liquid reservoir or other source. The conduits contain an electrically or other driven pump adapted to apply the necessary pressure to the liquid. Said conduits also contain a control valve to enable direction of flow of the liquid to be reversed or cut off, and an equalising valve to equalise the pressure supplied to the different cylinders. This equalising valve is controlled automatically by mechanism connected to the fore and aft links.

The stabilising floats, which in a central boat type of seaplane depend from the wings at a distance from the central boat, may be each carried on two pairs of parallel links, each link being composed of fore and aft struts with a diagonal strut or bracing members. These links allow lateral movement of the stabilising floats inboard of their lowered position so that each stabilising float may be raised during flight to nest-in and remain snug with an engine nacelle. The

[Price 1/-]

Price 4s 6d

stabilising floats are arranged to be lowered and raised, and retained in either the raised or lowered position, by block and tackle type mechanism, the tackle of which is arranged in a known manner to act on opposite sides of the float so that when the tackle at one side is pulled to move the float, the tackle at the other side is paid out. A separate block and tackle is provided for raising and for lowering the floats. The pulleys of each block are operable by hydraulic cylinders which act to separate the pulleys in each block. The hydraulic cylinders are each connected by a conduit to the liquid pressure supply for the pontoon, and contain a control valve which permits the liquid to be supplied to one or the other of the conduits or cuts

off the supply from both. The arrangement is such that when the liquid is being supplied through one conduit to one block, the liquid from the cylinder of the other block is allowed to return to the reservoir.

Indicators may be provided for indicating the positions of the pontoon and/or the stabilising floats, the indicators being operated by the mechanism controlling the equalising valve in the case of the pontoon and by one of the blocks in the case of the stabilising floats.

Dated this 13th day of February, 1935.
 BREWER & SON,
 33, Chancery Lane, London,
 Patent Agents for the Applicants.

COMPLETE SPECIFICATION

Improvements in and relating to Seaplanes

We, THE BLACKBURN AEROPLANE AND MOTOR COMPANY LIMITED, a Company organised under the Laws of Great Britain, and JOHN DOUGLAS RENNIE, a British Subject, both of Seaplane Base, Brough, near Hull, East Yorkshire, do hereby declare the nature of this invention and in what manner the same is to be performed, to be particularly described and ascertained in and by the following statement:—

This invention relates to seaplanes and refers more particularly to seaplanes of the type which are provided with a central float or boat with or without stabilising floats at either side thereof, said central float or boat or a section of it being arranged to be lowered for supporting the aircraft on the water and when the take-off has been accomplished such float, boat or section may be raised into positions where they create less drag than if they were maintained in the low position when the machine is water borne. Said stabilising floats may also be arranged so that they can be raised and lowered. The type is not confined to seaplanes which have only a single central float or boat, but also includes the case of two floats or boats, arranged side by side, one on either side of the longitudinal plane of symmetry of the aircraft.

With seaplanes, the float or boat when resting on the water determines the angular setting of the wing for the take-off, whereas in normal horizontal flight, the setting of the wings determines the position of the float or boat in such flight. Since, however, the wings require to have a much greater angle of attack at

the take-off than in normal flight it is not possible to set the wings relatively to the float or boat so that both the best angle of the wings relatively to the water for the take-off and also the best position of the float or boat for minimum drag in normal horizontal flight are obtained.

Now with a seaplane having a float, boat or section (hereinafter referred to as "the pontoon") arranged to be lowered for supporting the aircraft on the water, and to be raised for flight, the pontoon when lowered and floating on the water will determine the angular setting of the wings and at a certain position the wings will have an optimum value for take-off. Also, when the pontoon is raised for flight there will be relative to the wings a certain position of the pontoon (with or without a hull or body against which it may be retracted) which will give the best condition for flight.

To enable the best setting of the parts to be obtained according to this invention, the raising and lowering mechanism is arranged to produce a longitudinal tilting effect in raising and lowering the pontoon so as to give the optimum angular setting between the pontoon and the wing for take-off, and also the best wing setting relatively to the pontoon (with or without the hull or body against which it may be retracted) for flight conditions.

The raising and lowering of the pontoon may be effected in many ways, such as for instance, by fore and aft hydraulic cylinders. The pontoon may be carried on fore and aft links and these links may be parallel so as to permit the pontoon to

swing downwards and forwards when lowered, or upwards and rearwards when raised, by the hydraulic cylinders. These links are preferably in the form of frames having a wide base on the fixed portion of the hull or float and on the pontoon and the fore links are made longer than the aft links or otherwise arranged that the arc through which the aft links are swung is smaller than that of the fore links in order to provide the required longitudinal tilting effect of the pontoon. The aft hydraulic cylinder or cylinders are also made smaller than the fore cylinder or cylinders.

The hydraulic cylinders, of which there are preferably two forward and two aft, are in communication, by conduits forming a closed circulatory system, with a liquid reservoir or other source. The conduits contain an electrically or other driven pump adapted to apply the necessary pressure to the liquid. Said conduits also contain a control valve to enable the direction of flow of the liquid to be reversed or cut off, and an equalising valve to equalise the pressure supplied to the different cylinders. This equalising valve is controlled automatically by mechanism connected to the fore and aft links.

The stabilising floats, which in a central boat type of seaplane depend from the wings at a distance from the central boat, may be each carried in a known manner on one or more pairs of links, each link being composed of fore and aft struts with a diagonal strut or cross-bracing members. These links allow lateral movement of the stabilising floats inboard of their lowered position so that each stabilising float may be raised during flight to nest-in and remain snug with an engine nacelle. For this purpose the lower portion of the engine nacelle may be divided so as to form a float having a lower surface for resting in the water and an upper deck to exclude the entry of water to the float. The float, when swung inwards to the location of the engine nacelle, can be secured either by the hydraulic or other means employed for raising or swinging the pontoon inwards to the housing position, or by separate securing means to await release for being lowered and secured into the lowered position preparatory to alighting on the water.

The stabilising floats are arranged to be lowered and raised, and retained in either the raised or lowered position, by block and tackle type mechanism, the tackle of which is arranged in a known manner to act on opposite sides of the float so that when the tackle at one side

is pulled to move the float, the tackle at the other side is paid out. A separate block and tackle is provided for raising and for lowering the floats. The pulleys of each block are operable by hydraulic cylinders which act to separate the pulleys in each block. The hydraulic cylinders are each connected by a conduit to the liquid pressure supply for the pontoon, and contain a control valve which permits the liquid to be supplied to one or the other of the conduits or cuts off the supply from both. The arrangement is such that when the liquid is being supplied through one conduit to one block, the liquid from the cylinder of the other block is allowed to return to the reservoir.

When the seaplane has alighted on the water and the propeller is no longer in danger of contact with heavy water, the pontoon or lower section may be retracted and housed in the recess of the main upper portion of the hull against which it is stowed. The stabilising floats may also be raised when the seaplane is on the water, but in some constructions, by leaving the stabilising floats in the lower position, the seaplane may be held more steadily and prevented from canting over to an undesirable angle when afloat.

It will, of course, be understood that the pontoons when decked in have man-holes with coverings for giving access to such pontoons and which when raised may enter the upper portion of the hull. Thus, in large seaplanes the pontoon, which would naturally be of large displacement, can be utilised as a hull for occupation or for storage.

Indicators may be provided for indicating the positions of the pontoon and/or the stabilising floats.

A form of construction of a flying boat according to this invention is shown, by way of example, in the accompanying drawings, in which:—

Fig. 1 is a front elevation of the flying boat showing the pontoon and the stabilising floats in the lowered position which they occupy when the flying boat is floating on the water.

Fig. 2 is a side elevation of Fig. 1, but with the stabilising float removed.

Fig. 3 illustrates diagrammatically the mechanism for raising and lowering the pontoon and also raising and lowering the stabilising floats.

In the construction shown in the drawings, the hull of the boat is constructed with a main upper portion a and a lower portion or pontoon a^1 . The upper portion a has a water-tight under surface and the lower portion a^1 is formed as a

70

75

80

85

90

95

100

105

110

115

120

125

130

pontoon having a deck which fits against the under surface of the portion a when the pontoon is raised.

The pontoon is carried on fore and aft parallel links e and e^1 which permit the pontoon to swing downwards and forwards when lowered and upwards and rearwards when raised. These links are in the form of frames comprising lateral members, side members and diagonal members as shown in Fig. 1 and diagrammatically in Fig. 3. These frames have a wide base on the fixed portion of the hull of the boat and also on the pontoon.

There is attached to the pontoon near each corner of each frame a piston rod f of a hydraulic piston adapted to work in a cylinder f^1 which is mounted to oscillate about the pivot f^2 on the hull of the flying boat. The hydraulic pistons of which there are four, two at the front and two at the back, act to raise or to lower the pontoon, which is guided in its movement by the fore and aft links e and e^1 . The aft hydraulic pistons and cylinders are made smaller than the fore pistons or cylinders and the fore links are made longer than the aft links, so that for equal angular movements of the links the amount of movement imparted to the after end of the pontoon is smaller than the movement imparted to the fore end, the links being permitted a limited sliding movement in relation to either the hull or the pontoon to enable them to accommodate themselves to the changes which arise from the unequal movement of the pontoon. With this arrangement the pontoon, when raised, fits with its deck against the underside of the main upper portion a , and the hull composed of the upper portion a and the pontoon a^1 can be so designed that in this condition it will be in the best position relative to the wings for flight without regard to the angular setting of the wings for take-off, while when the pontoon is lowered, as shown in Figs. 1 and 2, the pontoon will be in such a position relative to the wings as will give the best angular setting of the wings for take-off.

The stabilising floats c and c^1 are carried on two pairs of parallel links, each being composed of fore and aft struts with a diagonal strut or bracing members. The stabilising floats are raised and lowered and are also retained in either of their terminal positions by block and tackle mechanism, the block for lowering the floats being marked h and that for raising the floats being marked i . These blocks are of duplex form and carry tackle for lowering or

raising both the port and the starboard floats. For instance the tackle h^1 for the port float is anchored at one end to the bracket h^2 , extends around a pulley h^3 and passes through the interior of the wing to a pulley h^4 before passing downwards to the port float to which its other end is attached. The tackle h^5 for the starboard float is attached at one end to the bracket h^2 and extends around the pulleys h^3 and h^6 before passing through the wing and round the pulley h^7 adjacent to the tip thereof to the starboard float. The tackle of the block i is arranged in a similar way to that of the block h and provides two oppositely extending cables i^1 , i^2 which, after passing around the pulleys i^3 and i^4 respectively, extend out to the stabilising floats to which they are attached.

The pulley h^3 in the block h is operable by a hydraulic cylinder h^8 which acts to separate this from the fixed bracket and pulley h^2 , while the movable pulleys in the block i are similarly actuated by the hydraulic cylinder i^5 .

The mechanism for raising and lowering the pontoon and also raising and lowering the stabilising floats is shown diagrammatically in Fig. 3 and comprises two sets of conduits g and g^1 connected to each hydraulic cylinder of the pontoon and forming a closed circulatory system. This circulatory system includes a liquid reservoir g^2 , a pump indicated at g^3 adapted to be driven by an electric motor indicated at g^4 and to apply the necessary pressure to the liquid for actuating the hydraulic pistons. Said conduits also contain a control valve g^5 which enables the direction of flow of the liquid to be reversed or to be cut off from the hydraulic cylinders. The links e , e^1 may be connected as indicated at g^9 to a red light g^{10} acting as a remote indicator which can be located in the cockpit for the purpose of indicating the position of the pontoon.

The cylinders h^8 and i^5 of the block and tackle mechanism for raising and lowering the stabilising floats are connected respectively by the conduits j , j^1 to the conduits g , g^1 hereinbefore described. These conduits j , j^1 contain a control valve j^2 which permits the liquid to be supplied through one or the other of the conduits to either the cylinder h^8 or the cylinder i^5 , or alternatively to cut off the supply through both of these conduits. This valve is so arranged that when fluid is flowing through one conduit the liquid is allowed to return through the other conduit to the reservoir g^2 , so that, for

- instance, when the block *h* is operated the tackle *h*¹, *h*⁵ will be pulled to lower the floats. In this case, the floats will have been held in their retracted position 5 by the tackle *i*¹, *i*² and the action of lowering these floats will be to draw this tackle and cause it to close up the block *i*, thus expelling the liquid from the hydraulic cylinder *i*⁵ to the reservoir *g*².
- 10 In a similar manner, when the block *i* is being operated, the tackle on the block *h* will actuate this block and expel the liquid from the cylinder *h*⁸. Consequently, by cutting off the supply and 15 return of the liquid to the cylinders *h*⁸, *i*⁵, the liquid will be trapped in these cylinders and thus the tackle will act to retain the floats in any adjusted position. The position of the stabilising floats may 20 be indicated by connecting the cylinder *h*⁸ by remote control means indicated at *k* to a red light *k*¹ acting as a remote indicator which may be located in the pilot's cockpit.
- 25 Having now particularly described and ascertained the nature of our said invention and in what manner the same is to be performed, we declare that what we claim is:—
- 30 1. A seaplane having its float, boat, or a section of the float or boat, arranged to be raised or lowered by mechanism which produces a longitudinal tilting effect so as to enable the optimum angular setting 35 between the float, boat or section and the wing for take-off and also the best wing setting relatively to the pontoon (with or without the hull or body against which it may be retracted) for flight 40 conditions to be obtained.
2. A seaplane as claimed in Claim 1, in which the raising and lowering of the float, boat or section is effected by fore and aft hydraulic cylinders.
- 45 3. A seaplane as claimed in Claim 1, in which the float is carried on fore and aft links, the fore links being longer than the aft links so that the arc through which the ends of the aft links is swung 50 is smaller than that of the ends of the fore links.
4. A seaplane as claimed in Claim 2, in which the hydraulic cylinders are in communication, by conduits forming a 55 closed circulatory system, with a liquid reservoir or other source, and containing a pump for applying the necessary pressure to the liquid.
5. A seaplane as claimed in Claim 4, in which the conduits also contain a 60 control valve to enable the flow of liquid to be reversed or cut off.
6. A seaplane as claimed in any of the preceding Claims, having a combination 65 with the main float, boat or section, stabilising floats carried on one or more links which allow lateral movement to permit said floats to be raised during 70 flight to nest-in and remain snug with an engine nacelle, in which the stabilising floats are raised and lowered, and retained in the raised or lowered 75 position, by the hydraulic devices provided for raising and lowering the said float, boat or section.
7. A seaplane as claimed in Claim 6, in which the stabilising floats are raised and lowered and retained by block and 80 tackle mechanism, which is actuated by said hydraulic devices.
8. A seaplane as claimed in Claim 7, in which separate blocks and tackle are provided for raising and for lowering 85 the floats.
9. A seaplane as claimed in Claim 8, in which the pulleys of each block are operable by hydraulic cylinders which 90 act to separate said pulleys.
10. A seaplane as claimed in Claim 9, in which the hydraulic cylinders are each 95 connected by a conduit to the liquid pressure supply for the float, boat or section.
11. A seaplane as claimed in Claim 10, in which the conduits contain a control 100 valve which permits the liquid to be supplied through one or the other of the two conduits or cuts off the supply from both.
12. A seaplane as claimed in any of the 105 preceding Claims, in which indicators are provided for indicating the positions of the said float, boat or section and/or of the stabilising floats.
13. A seaplane having a float, boat or 110 section adapted to be raised or lowered with or without stabilising floats substantially as herein described with reference to the accompanying drawings.

Dated this 13th day of February, 1935.

BREWER & SON,
33, Chancery Lane, London,
Patent Agents for the Applicants.

[This Drawing is a reproduction of the Original on a reduced scale.]

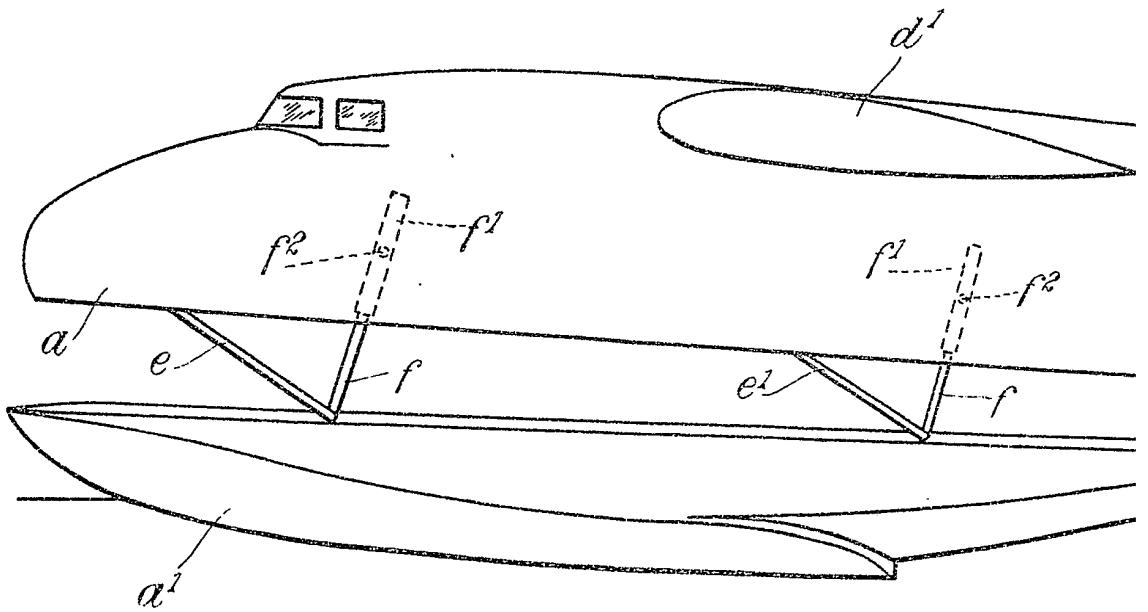
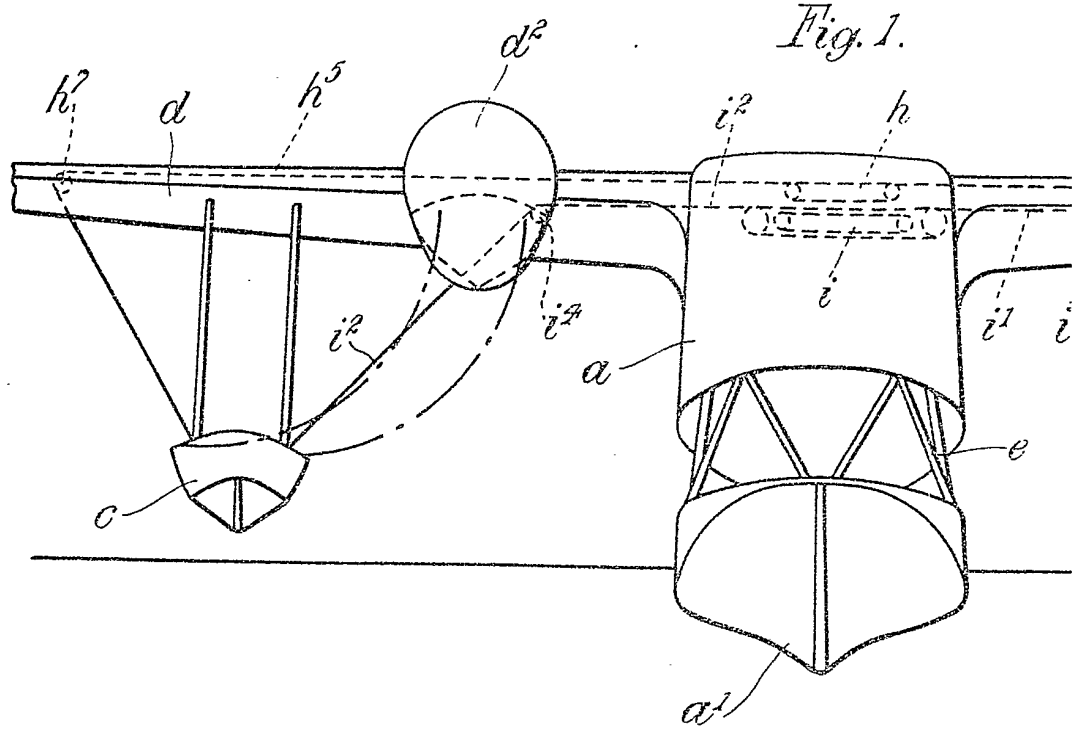

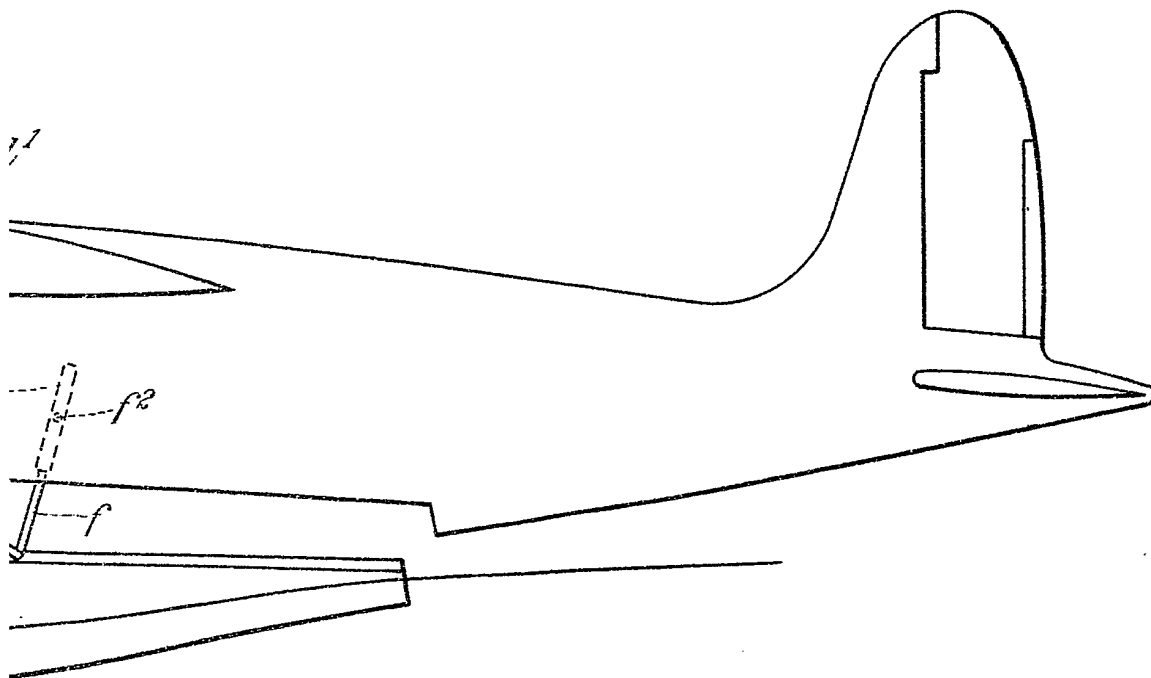
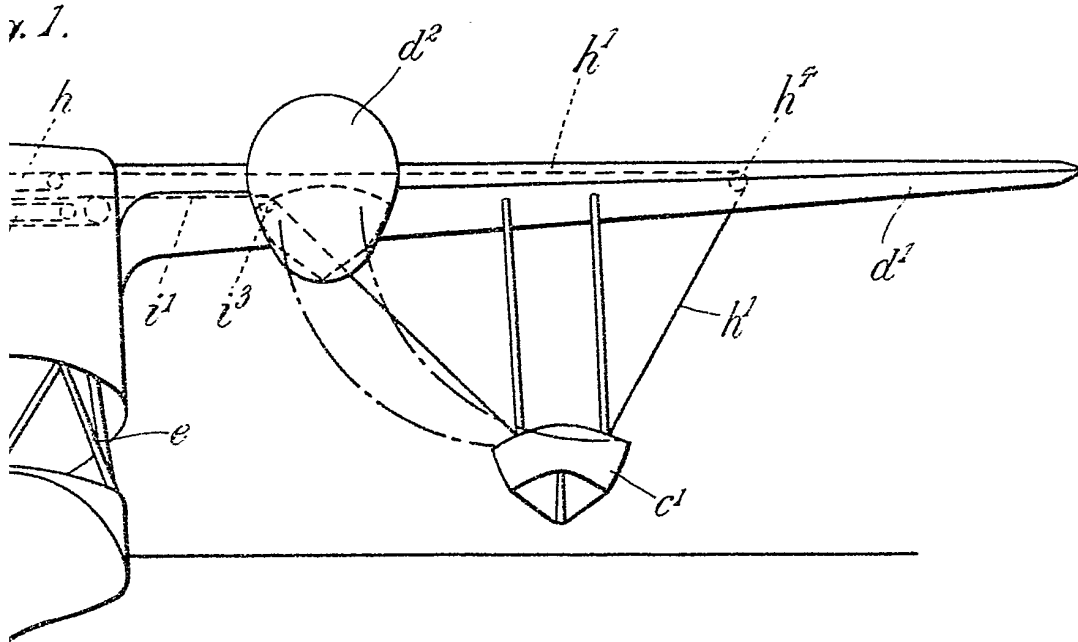

Fig. 2.

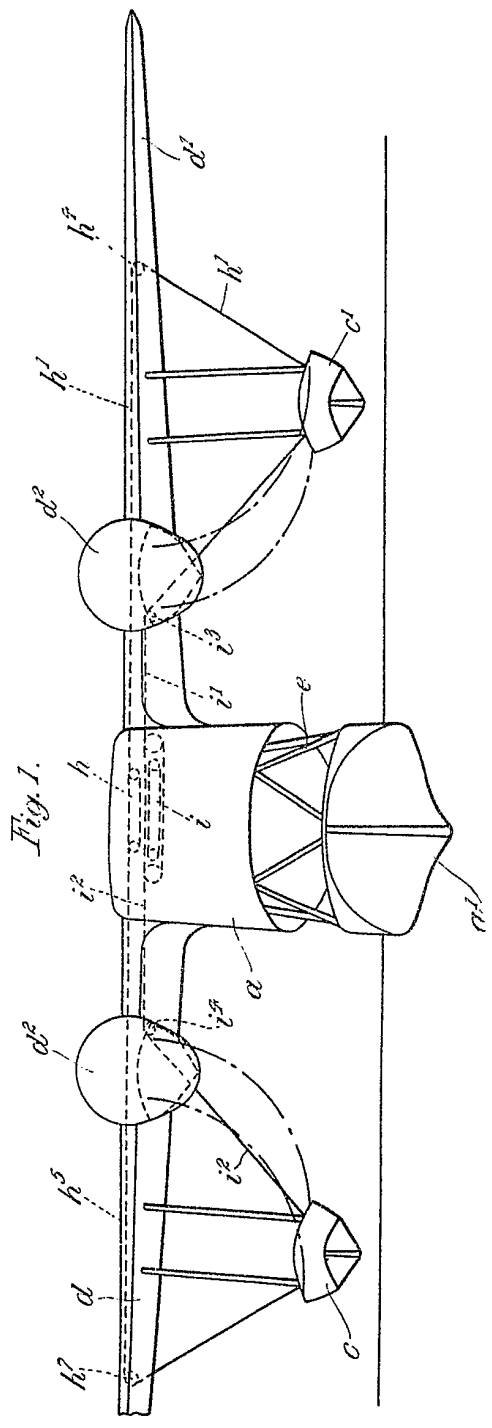

Fig. 1.

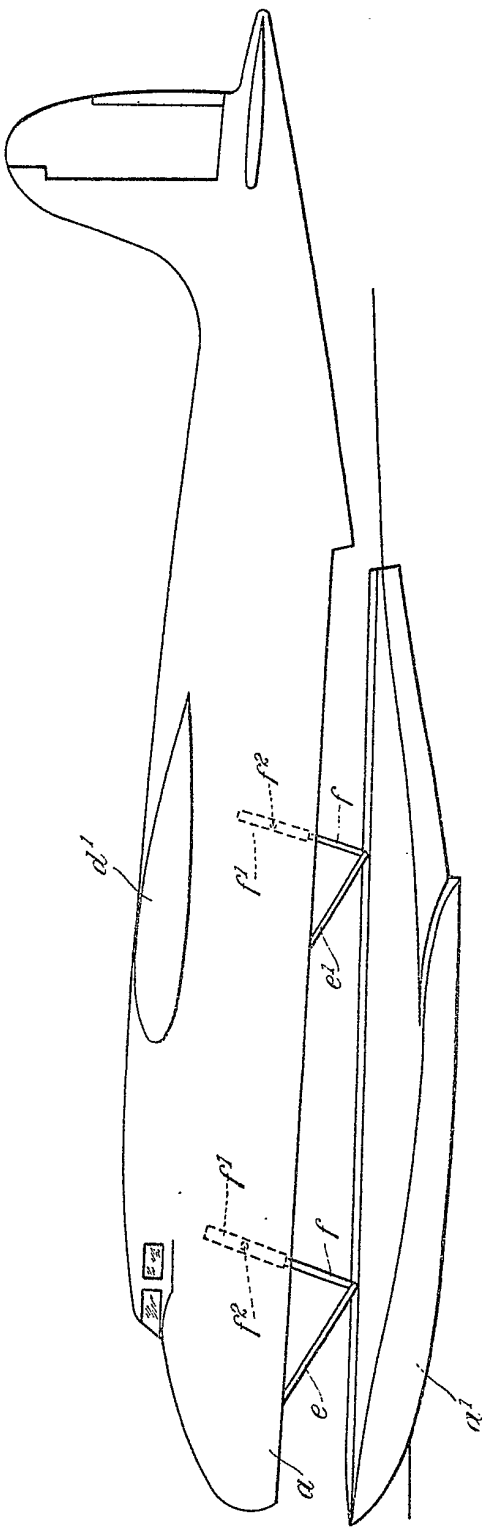
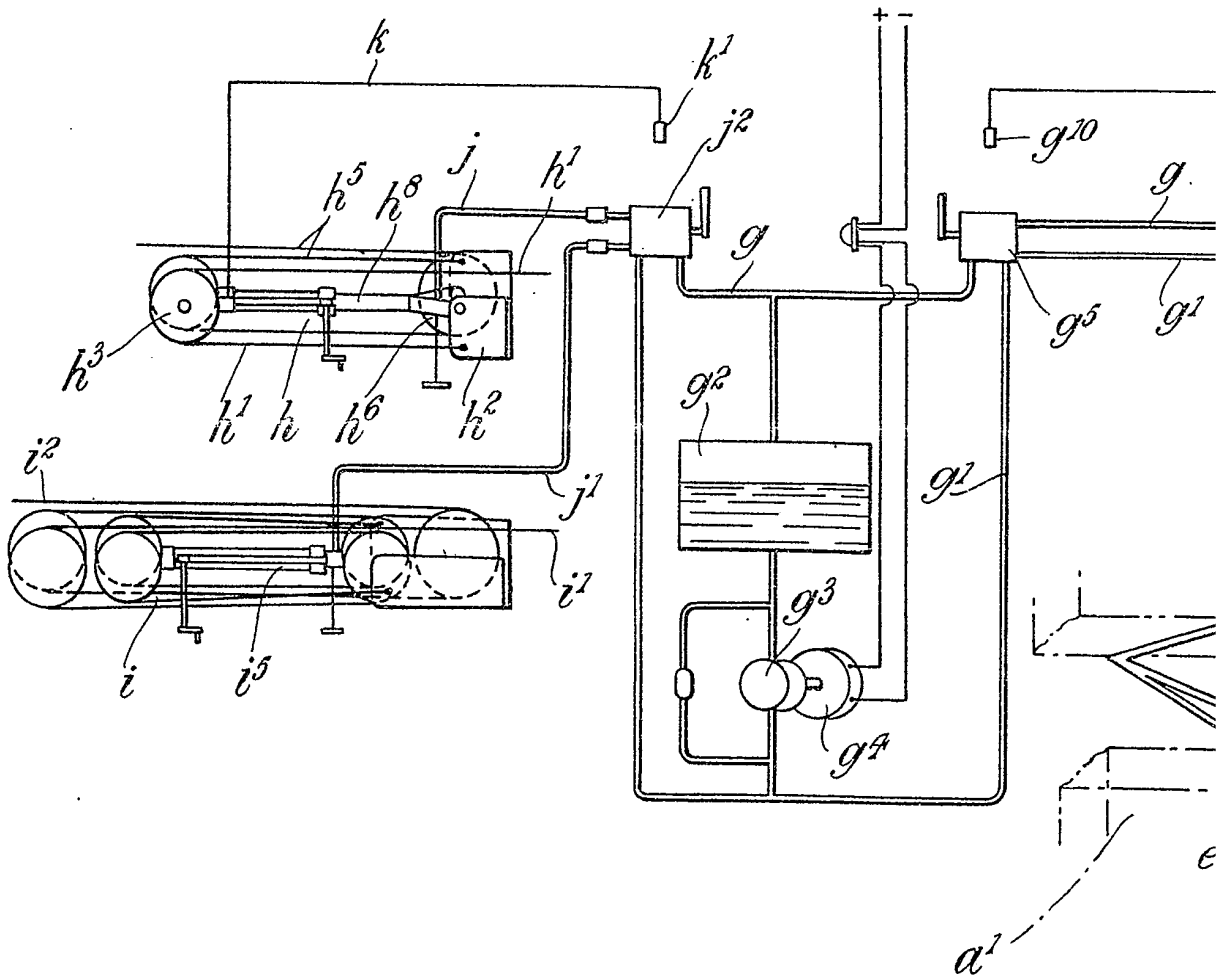

Fig. 2.

[This Drawing is a reproduction of the original on a reduced scale.]

Fig. 3.

[This Drawing is a reproduction of the Original on a reduced scale.]



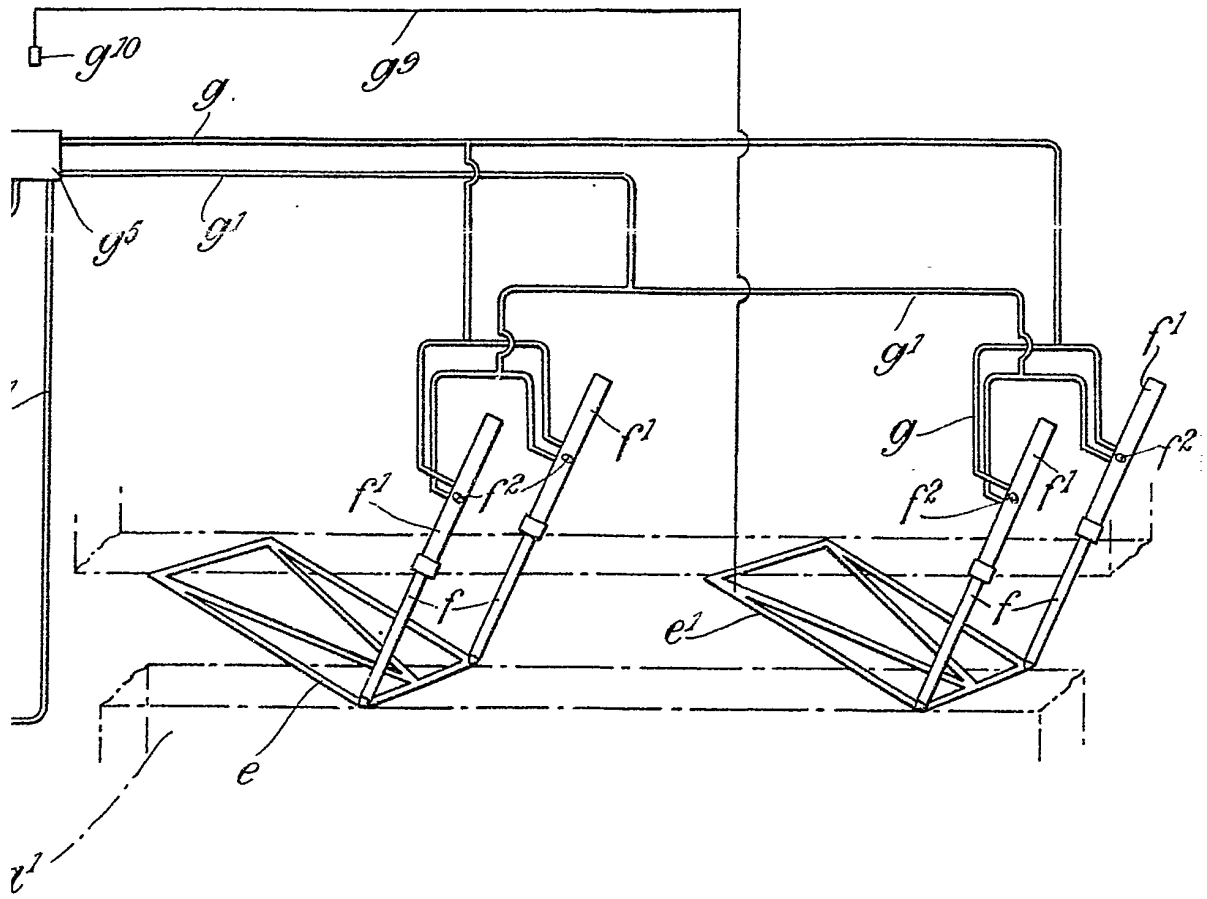

Fig. 3.

[This Drawing is a reproduction of the Original on a reduced scale.]

